

# shindaiwa®

Brand perception survey



Know more about Shindaiwa



Diesel Engine Driven Welder  
**DGW500DM-D4CV**

Semi Automatic Wire Feeder  
**SWF500**



Shindaiwa Welder Introduction



Shindaiwa SWF500 Introduction





shindaiwa®

# DGW500DM-D4CV

DIESEL ENGINE DRIVEN WELDER



shindaiwa®

# SWF500

SEMI AUTOMATIC WIRE FEEDER



## RealDual®



- Light weight, high performance
- Rated output 500A
- Strong feeding performance from 4 Gear Drive
- IP23 rated protection



### Durable electronic component

Special protection over precision parts

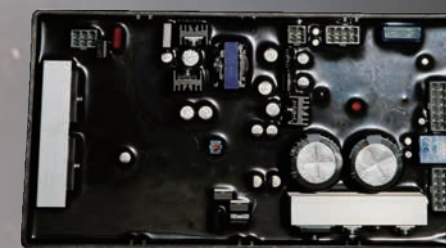

### Distinctive cooling system

Realized long time operation and weight reduction

## RealDual®

Dual welding mode



Japanese regulation compliant

Tier 3 Quiet



CC/CV Welding mode

CC: Constant Current  
CV: Constant Voltage



### VRD

VRD: Voltage Regulation Device  
Safety enhancement



### SPECIFICATIONS

		Single	Dual
Rated Current (A)		480	230
Duty Cycle (%)		60	80
Current Adj. Range (A)		600-500	30-230
Welding mode selector		CC/CV	
VRD Function		YES	
VRD Switch		ON/OFF	
VRD Lamp		NO	
Noise Level (dB(A))		64	
Engine Model		KUBOTA V1505	

Powered by Kubota

### SPECIFICATIONS

Rated output (60%)	500A
Rated output (100%)	340A
Operating temperature	-40 ~ 40°C
Applicable wire diameter	Self-shield 0.9 ~ 2.4
	Solid 0.9 ~ 1.6
	Flux 0.9 ~ 1.6
Drive system	Four-wheel
Wire feeding speed	50 ~ 700 inch/min
	1.3 ~ 17.7 m/min
Dry or maintenance weight	16kg
External dimensions	L561 x W211 x H428mm

### Strong feeding performance

The unique 4 Gear Drive system provides industry leading wire feeding performance.





# Accessory List

#	Item Name	Picture	Item Code	Note
1	CORD		G361000810	Extension control cable 10m
			G361000820	Extension control cable 20m
2	CORD		G361000750	Extension Power cable 10m
			G361000770	Extension Power cable 20m
3	JOINT, CABLE		C481000050	Cable joint (male/female) 60mm2
4	JOINT, CABLE		C481000060	Cable joint (male) 100mm2
5	CLIP		V490001650	Earth
6	HOSE		K400003750	Gas hose 10m, hose joint set
			K400003760	Gas hose 20m, hose joint set
7	TCSH45NOG-LN3		56604062	Welding torch for self shield
	TCSH35-LN3		56604210	Welding torch for Gas

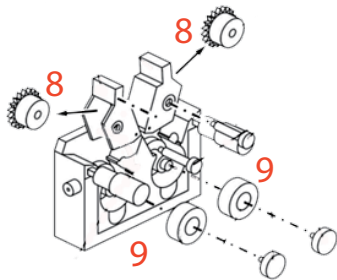
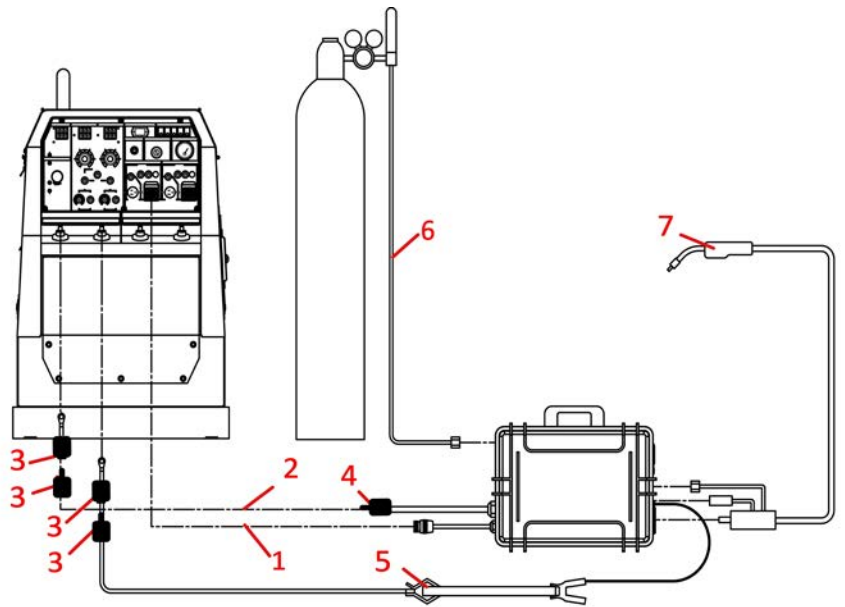

#	Item Name	Picture	Item Code	Note	Self Shield	Gas
8	ROLLER		V460000510	Pressure roller 1.0	o	
			V460000520	Pressure roller 1.2	o	
			V460000590	Pressure roller 1.4	o	
			V460000530	Pressure roller 1.6	o	
			V460000550	Pressure roller 1.8	o	
			V460000540	Pressure roller 2.0	o	
			V460000500	Pressure roller 2.4	o	
			V460000620	Pressure roller 0.8		o
			V460000630	Pressure roller 1.0		o
			V460000600	Pressure roller 1.2		o
9	ROLLER		V460000560	Feed roller 1.0/1.2	o	
			V460000570	Feed roller 1.2/1.4	o	
			V460000490	Feed roller 1.6/2.4	o	
			V460000580	Feed roller 1.8/2.0	o	
			V460000650	Feed roller 0.8/1.0		o
			V460000610	Feed roller 1.2/1.6		o

#	Item Name	Picture	Item Code	Note	Self Shield	Gas
10	TIP		M128000000	Tip 0.9	o	o
			M128000010	Tip 1.2	o	o
			M128000060	Tip 1.6	o	o
			M128000070	Tip 2.0	o	o
			M128000080	Tip 2.4	o	o
11	TUBE		V475009790	Liner 0.9	o	o
			V475009800	Liner 1.2	o	o
			V475009820	Liner 1.6	o	o
			V475009810	Liner 2.0	o	o
			V475009830	Liner 2.4	o	o
12	NOZZLE		E298000090	Nozzle	o	
			E298000100	Nozzle		o
13	COVER		M471001200	Cover	o	o

